



ZAVAGLI
NATI PER SOLLEVARE 



ZAVAGLI.IT

VIALE J. F. KENNEDY, 99
50038 - SCARPERIA E SAN PIERO - FIRENZE - ITALIA

Descrizioni e disegni hanno carattere informativo. Le immagini, le informazioni, i dati tecnici e le caratteristiche tecniche riportate su listini, cataloghi e siti internet sono puramente indicative, non sono integrative, non costituiscono documento contrattualmente vincolante e possono subire variazioni senza preavviso. ZAVAGLI si riserva il diritto di modificare i dati tecnici in qualsiasi momento, senza preavviso e senza responsabilità ed obbligo, apportando aggiornamenti in linea con i continui miglioramenti dei prodotti. Description and pictures are indicative. Any description given or applied to the products is given by way of identification only and the use of such description shall not constitute a sale by description. For the avoidance of doubt, the buyer hereby affirms that it does not in any way rely on any description when entering into the contract. Note of the information contained in the catalogues or www.zavagli.it or shop.zavagli.it constitutes a legally binding document. ZAVAGLI reserves the right to modify pictures, specifications and options at any time and without notice. The actual product may vary due to product enhancements.

ES1

ZAVAGLI
NATI PER SOLLEVARE 

Z61 - Z61 3S - Z61 3SL - Z61 3SLB



Z61 3S

	Z61/3S
PORTATA Capacity - Portée - Leistung - Capacidad	Kg 3.500
MOTORE Motor - Moteur - Motor - Motor	Kw 3
VOLTAGGIO Voltage - Spannung - Voltage - Voltaje	V 380 50/60 hz
TEMPO DI SALITA Rasing time - Temps de montée Hubzeit Tiempo de subida	m/sec. 0,033
TEMPO DI DISCESA Lowering time - Temps de descente Senkseit - Tiempo de bajada	m/sec. 0,033

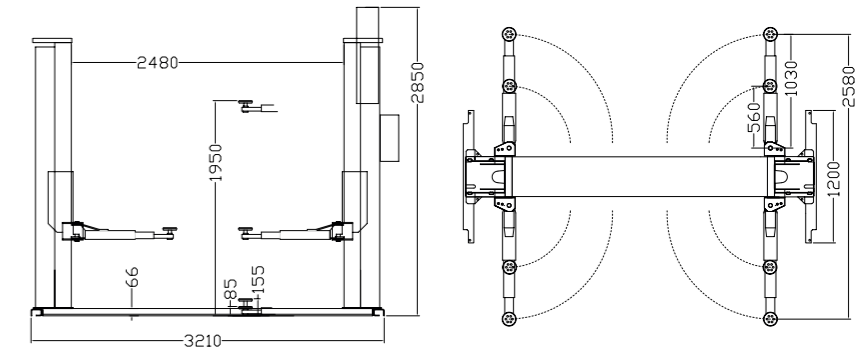

Z61 3SL

	Z61/3SL
PORTATA Capacity - Portée - Leistung - Capacidad	Kg 3.500
MOTORE Motor - Moteur - Motor - Motor	Kw 3
VOLTAGGIO Voltage - Spannung - Voltage - Voltaje	V 380 50/60 hz
TEMPO DI SALITA Rasing time - Temps de montée Hubzeit Tiempo de subida	m/sec. 0,033
TEMPO DI DISCESA Lowering time - Temps de descente Senkseit - Tiempo de bajada	m/sec. 0,033

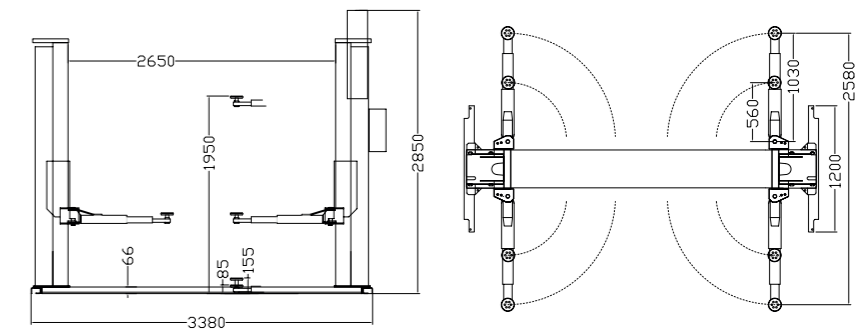

Z61 3SLB

	Z61/3SLB
PORTATA Capacity - Portée - Leistung - Capacidad	Kg 3.500
MOTORE Motor - Moteur - Motor - Motor	Kw 3
VOLTAGGIO Voltage - Spannung - Voltage - Voltaje	V 380 50/60 hz
TEMPO DI SALITA Rasing time - Temps de montée Hubzeit Tiempo de subida	m/sec. 0,033
TEMPO DI DISCESA Lowering time - Temps de descente Senkseit - Tiempo de bajada	m/sec. 0,033

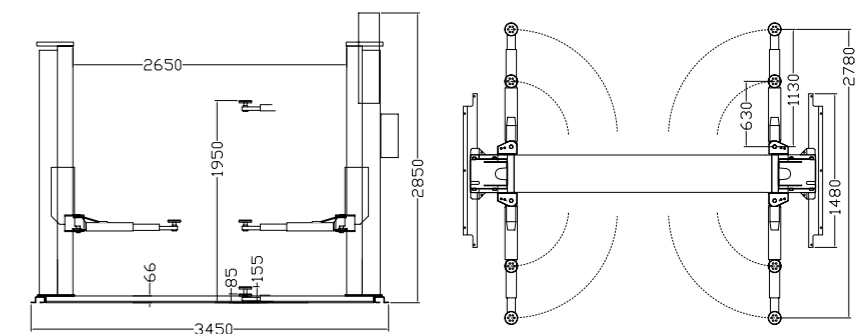

PONTI SOLLEVATORI

ELETTROIDRAULICI

